

# General Specifications

## VJB1 CT Converter (RMS)

**JUXTA**

GS 77J01B01-01E

### General

The VJB1 is a compact, plug-in CT converter that converts AC current signal from a current transformer (CT) into isolated DC voltage or DC current signals.

- input, output and power supply terminals that are all isolated from each other;
- AC-to-DC conversion based on RMS rectification;
- a withstanding voltage of 2000 V AC;
- a wide supply voltage range - supporting both 100 V and 200 V power lines of AC or DC; and
- close side-by-side mounting.

### Model and Suffix Codes

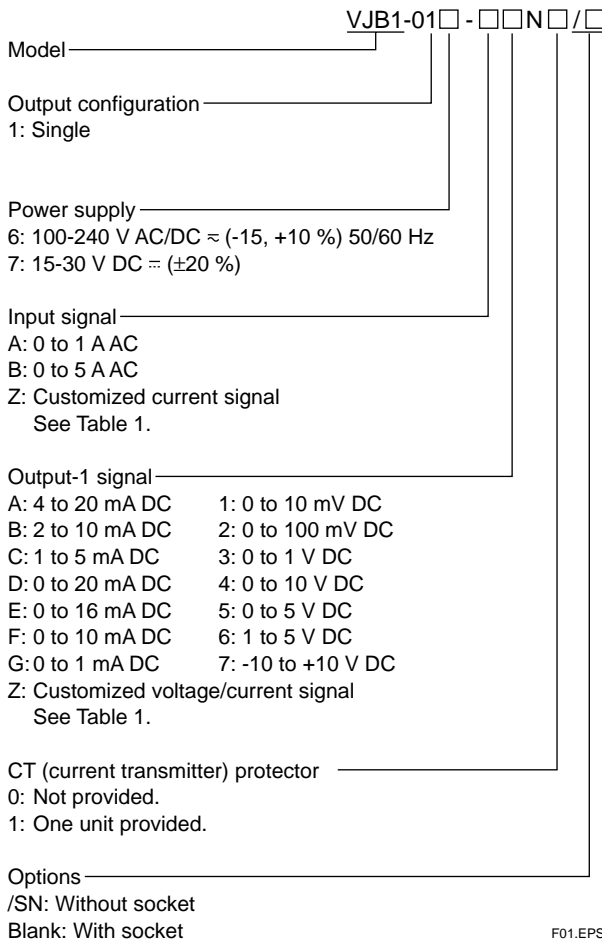

### Input/Output Specifications

Type of input: 0 to 1 or 0 to 5 A AC signal  
 Input loss: 0.5 VA maximum  
 Input frequency range: 40 Hz to 10 kHz  
 Maximum allowable overrange input: 120% (continuous);  
 500% (for five seconds)  
 Output signal: DC voltage or DC current  
 Allowable load resistance:

Output Range	Output Range
4 to 20 mA DC: 750 $\Omega$ maximum	0 to 10 mV DC: 250 k $\Omega$ minimum
2 to 10 mA DC: 1500 $\Omega$ maximum	0 to 100 mV DC: 250 k $\Omega$ minimum
1 to 5 mA DC: 3000 $\Omega$ maximum	0 to 1 V DC: 2 k $\Omega$ minimum
0 to 20 mA DC: 750 $\Omega$ maximum	0 to 10 V DC: 10 k $\Omega$ minimum
0 to 16 mA DC: 900 $\Omega$ maximum	0 to 5 V DC: 2 k $\Omega$ minimum
0 to 10 mA DC: 1500 $\Omega$ maximum	1 to 5 V DC: 2 k $\Omega$ minimum
0 to 1 mA DC: 15 k $\Omega$ maximum	-10 to +10 V DC: 10 k $\Omega$ minimum

Zero and span adjustment: Within  $\pm$ 5% of span for both zero and span adjustment

### Standard Performance

Accuracy rating:  $\pm$ 0.5% of span; accuracy is not guaranteed for output level less than 0.5% of the span of a 0 to X mA output range type.  
 Response: 175 ms for a 63% response (10 to 90% change of range)  
 Insulation resistance: 100 M $\Omega$  minimum at 500 V DC between input, output, power supply and grounding terminals mutually  
 Withstanding voltage: 2000 V AC for one minute between input, output, power supply and grounding terminals mutually  
 Operating temperature range: 0 to 50°C  
 Operating humidity range: 5 to 90% RH (no condensation)  
 Supply voltage range: 100-240 V AC/DC  $\approx$  (-15, +10%) 50/60 Hz or 15-30 V DC  $\approx$  ( $\pm$ 20%)  
 Effects of power line regulation: Up to  $\pm$ 0.1% of span for a supply voltage range of 85 to 264 V AC (47 to 63 Hz), 85 to 264 V DC or 12 to 36 V DC  
 Effects of ambient temperature variations: Up to  $\pm$ 0.2% of span per 10°C  
 Current consumption: 87 mA at 24 V DC  
 Power consumption: 5.5 VA at 100 V AC; 7.4 VA at 200 V AC

### Items to be specified when ordering

- Model and Suffix Code: e.g. VJB1-016-BAN0

## ■ Mounting and Appearance

Material: ABS resin (casing)

Mounting: Wall mounting, DIN rail mounting, or  
mounting on a side-by-side multiple mounting  
base

Connection: Terminals with M3 size screws

External dimensions: 76 (H) × 29.5 (W) × 124.5 (D) mm

Weight: Main unit = approx. 122 g; socket = approx. 51 g

## ■ Accessories

Tag number label: One

## ■ Customized Signal Specifications

**Table 1 Manufacturable Ranges**

	<b>Current Signal</b>	<b>Voltage Signal</b>
Input range	0 to 5 A AC (where, the value of "5/I <sub>100</sub> [I <sub>100</sub> = current for 100% input]" equals a real integer)	–
Span	0.1 to 5 A AC	–
Zero elevation	0% only	–
Output range	0 to 24 mA DC	-10 to +10 V DC
Span	1 to 24 mA DC	10 mV to 20 V DC
Zero elevation	0 to 200%	-100% to +200%

T01.EPS

### Terminal Assignments

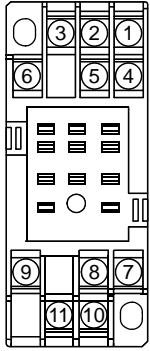

1	INPUT	(A)
2	N.C.	
3	INPUT	(±)
4	N.C.	
5	N.C.	
6	N.C.	
7	OUTPUT	(+)
8	GND	
9	OUTPUT	(-)
10	SUPPLY	(L+)
11	SUPPLY	(N-)

F03.EPS

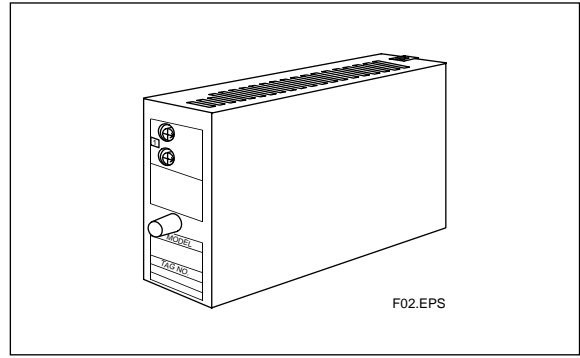

### CAUTION

It is recommended that CT protector (CTG-5) be attached to the current input terminals connected to the secondary stage of the CT. Since a high potential develops over the secondary stage, the CT may burn and break if you unplug the main unit from the socket while the transmitter is turned on and it has no CT protector.

### Block Diagram

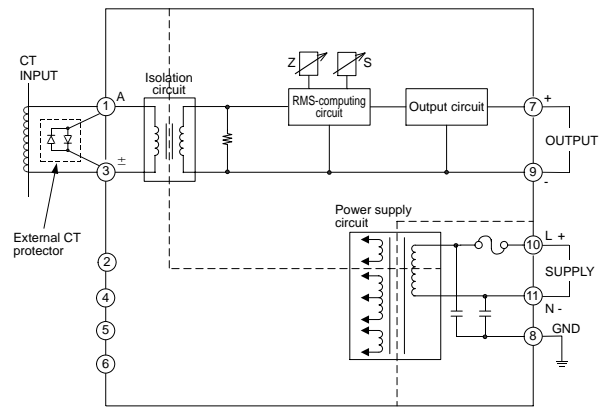

F04.EPS

### External Dimensions

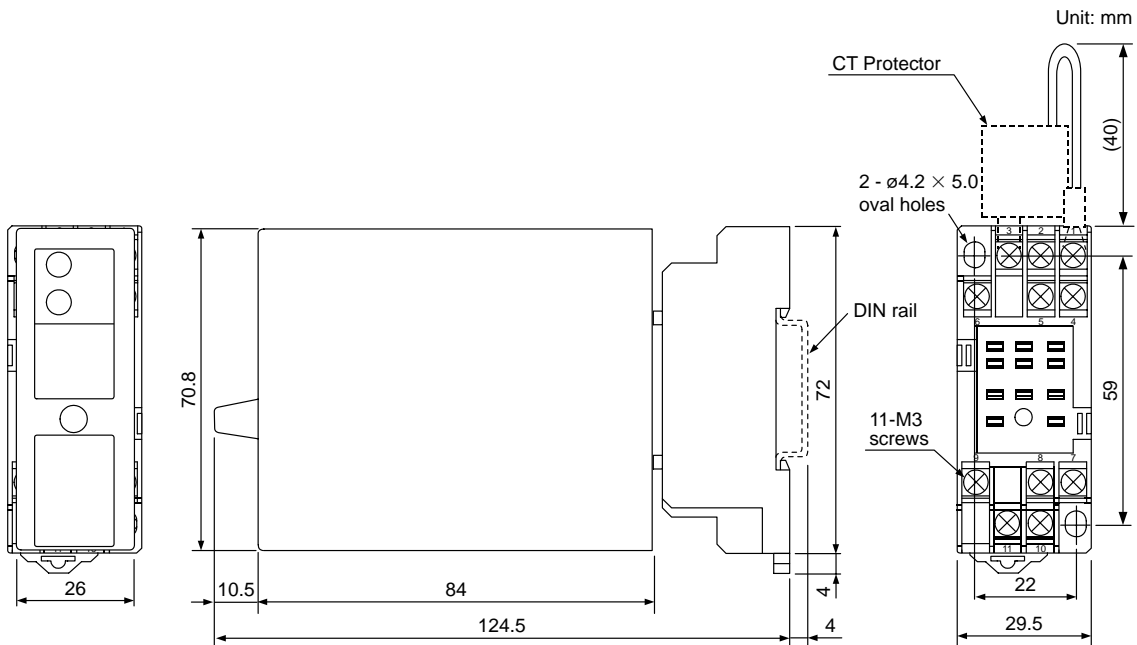

F05.EPS

- The information covered in this document is subject to change without notice for reasons of improvements in quality and/or performance.